



**IMPACT® SR LHVD
DISPOSABLE FILTERS**

*Rapid changeout, all-Teflon® fluoropolymer filter
for point-of-use filtration of aggressive solvents*



the solution for filtration of aggressive solvents

Overview

Impact® SR LHVD disposable filters have been optimized for use with the IntelliGen® photochemical dispense system to deliver the best filtration and dispense characteristics in the industry.

Superior Design

- All-Teflon® fluoropolymer construction to ensure compatibility with aggressive solvents
- Rapid filter changeout with minimal dripping; with NO tools and NO draining required, you can change the filter in less than one minute
- Low holdup volume minimizes wasted chemicals

Superior Manufacturing

- Manufactured in a world-class, ISO 9001 Quality Systems Standard facility
- Manufactured, tested, and packaged in a cleanroom to ensure product cleanliness
- Each filter is 100% integrity tested prior to shipment

Applications

- For use with the IntelliGen photochemical dispense system and Impact ST manifold
- For small- to mid-volume point-of-use aggressive solvent filtration applications

Features	Benefits
PTFE pleated membrane and PFA construction	Provides maximum chemical compatibility; can be used with all chemicals, including aromatics and ketone solvents.
Design optimized for use with the IntelliGen photochemical dispense system and Impact ST manifold	Rapid filter changeout and ease of use to maximize equipment uptime. (Prewetting may be required with fluids above 29 dynes/cm).
Self-contained, disposable design	Disposable design minimizes exposure to chemicals, providing improved user safety.
Unique configuration of the housing and membrane	Ensures superior bubble venting and microbubble prevention to lower defects caused by bubbles and microbubbles.
Small footprint, low holdup volume	Low holdup volume reduces chemical waste, lowering cost and overall equipment COO.

Specifications

Materials:	Membrane	PTFE
	Supports, core, sleeve, shell	PFA
Dimensions:	Height	89.5 mm \pm 1 mm (3.52" \pm 0.04")
	Width	71.5 mm \pm 1 mm (2.81" \pm 0.01")
Membrane area:	600 cm ² (93 in ²)	
Holdup volume:	\leq 45 cc	
Maximum operating conditions:	Maximum inlet pressure	3.9 bar (56.6 psid, 4.0 kg/cm ²) @ 25°C (77°F)
	Maximum forward/reverse differential pressure	0.29 MPa (2.9 bar, 42 psi) @ 25°C (77°F)
	Maximum operating temperature	30°C (86°F)
Compatibility:	All photochemical solvents	
Wettability:	Prewetting should be considered with higher surface tension solvents such as NMP, cyclohexanone, GBL, EGMEA, ethyl lactate and MMP	

Dimensions

Impact SR LHVD

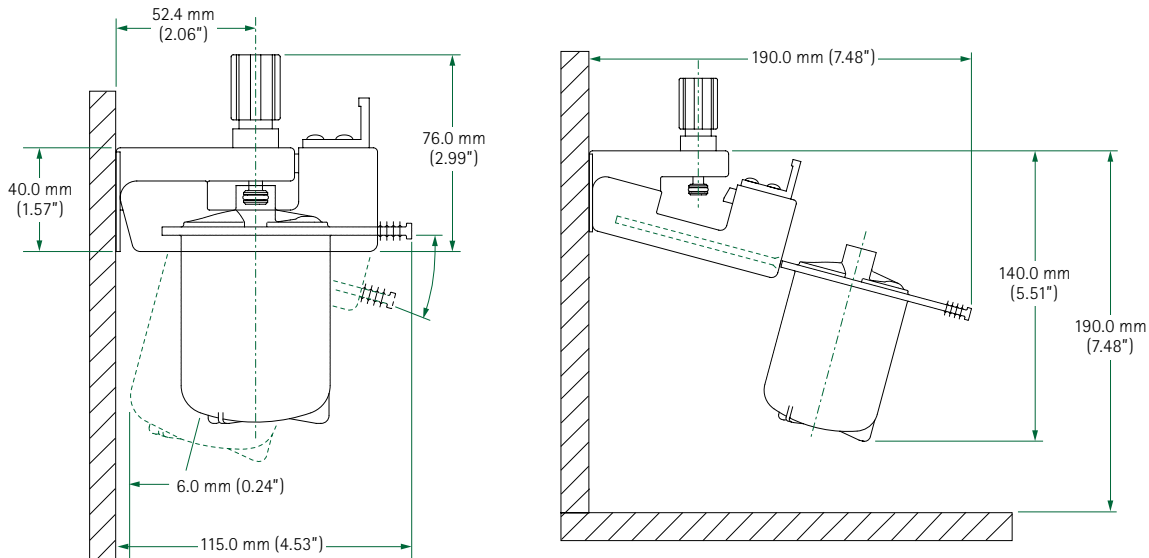

Performance Data

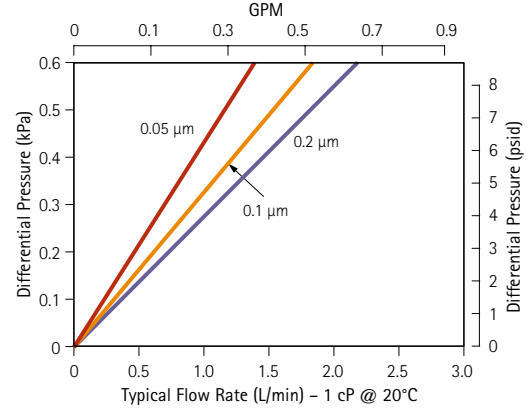
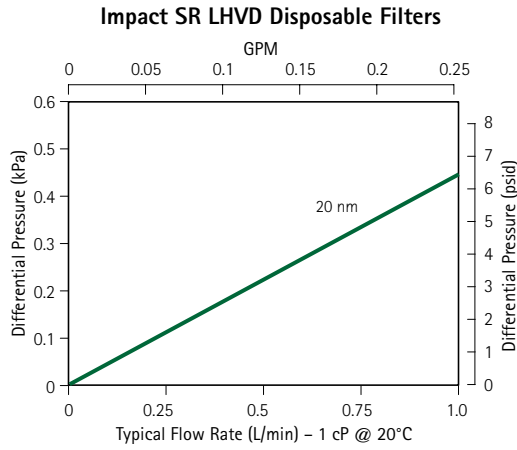

Ordering Information

Part Number	Description	Pore Size
ATX 000 01	Impact SR LHVD TR filter	20 nm
ATFZ 000 01	Impact SR LHVD filter	0.05 µm
ATFV 000 01	Impact SR LHVD filter	0.1 µm
ATFG 000 01	Impact SR LHVD filter	0.2 µm

For More Information

Please call your Regional Customer Service Center today to learn what Entegris can do for you. Visit www.entegris.com and select the Customer Service link for the center nearest you.

Terms and Conditions of Sale

All purchases are subject to Entegris' Terms and Conditions of Sale. To view and print this information, visit www.entegris.com and select the Legal Notices link from the footer.

Entegris®, IntelliGen® and Impact® are registered trademarks of Entegris, Inc. Teflon® is a registered trademark of E.I. du Pont de Nemours and Company.

ENTEGRIS, INC.

Corporate Headquarters | 129 Concord Road | Billerica, MA 01821 USA
 Customer Service Tel. +1 952 556 4181 | Customer Service Fax +1 952 556 8022
 In North America 800 394 4083 | www.entegris.com