



## LINEGARD™ MAX-FP IN-LINE TEFLON® GAS FILTERS

Cost-effective 0.003 µm filters for mid-flow range on noncritical applications

### Overview

Linegard™ MAX-FP in-line Teflon® gas filters with a particle removal rating of > 0.003 µm are designed as cost-effective solution for mid-flow range on noncritical applications. Recommended for filtration of compressed dry air and inert gases such as general nitrogen on applications of instrument air, air knife, purge/vent line, hook up and dryer.

### Features and Benefits

- Filter element –Teflon PTFE membrane supported by polypropylene structures – provides a cost-effective solution for filtration of compressed air and inert gases
- Large inside diameter of filter element is designed for high flow rate/low pressure drop, resulting in up to 1000 SLPM with compact housing
- Various fitting and length configurations provide ease of installation without design changes of gas panel and delivery system



### Specifications

Materials:	Membrane	PTFE
	Supports	Polypropylene
	O-ring	Fluoroelastomer (FKM)
	Housing	316L Stainless steel
Surface finish interior:	25 µin Ra	
Removal rating:	> 0.003 µm (in gas)	
Maximum operating conditions:	Maximum inlet pressure	70 bar (1015 PSIG)
	Maximum forward differential pressure	4.1 bar (59 PSID)
	Maximum reverse differential pressure	2 bar (29 PSID)
	Maximum operating temperature	60°C (140°F)
Helium leak rating:	1 × 10 <sup>-10</sup> Pa•m <sup>3</sup> /sec	
Recommended gases:	Compressed dry air (CDA) and inert gases	
Warranty:	1 year	

Please consult your Application Specialist or Technical Service for compatibility with other gases.

## Dimensions

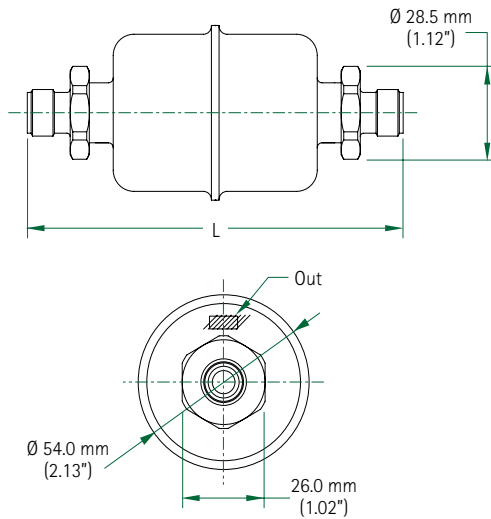

## Ordering Information

Part Number	Fitting	Length
LGMX FP SS2	1/4" Swagelok® compatible	112.7 mm (4.44")
LGMX FP SS2L	1/4" Swagelok compatible (long length)	141.0 mm (5.55")
LGMX FP SS3	3/8" Swagelok compatible	117.9 mm (4.64")
LGMX FP SS3L	3/8" Swagelok compatible (long length)	148.0 mm (5.83")
LGMX FP SS4	1/2" Swagelok compatible	118.7 mm (4.67")
LGMX FP RR2	1/4" Male VCR® compatible	127.0 mm (5.00")
LGMX FP RR4	1/2" Male VCR compatible	127.0 mm (5.00")
LGMX FP BB2	1/4" Female NPT	131.8 mm (5.19")

## For More Information

Please call your Regional Customer Service Center today to learn what Entegris can do for you. Visit [www.entegris.com](http://www.entegris.com) and select the Customer Service link for the center nearest you.

## Terms and Conditions of Sale

All purchases are subject to Entegris' Terms and Conditions of Sale. To view and print this information, visit [www.entegris.com](http://www.entegris.com) and select the Legal Notices link from the footer.

Entegris® and Linegard™ are trademarks of Entegris, Inc.  
Teflon® is a registered trademark of E.I. du Pont de Nemours and Company.  
VCR® and Swagelok® are registered trademarks of Swagelok Company.

### ENTEGRIS, INC.

Corporate Headquarters | 129 Concord Road | Billerica, MA 01821 USA  
Customer Service Tel. +1 952 556 4181 | Customer Service Fax +1 952 556 8022  
In North America 800 394 4083 | [www.entegris.com](http://www.entegris.com)

©2009–2011 Entegris, Inc. All rights reserved Printed in USA 4502-5786ENT-0611

## Performance Data

### Linegard MAX-FP 1/4" Fittings (except NPT)

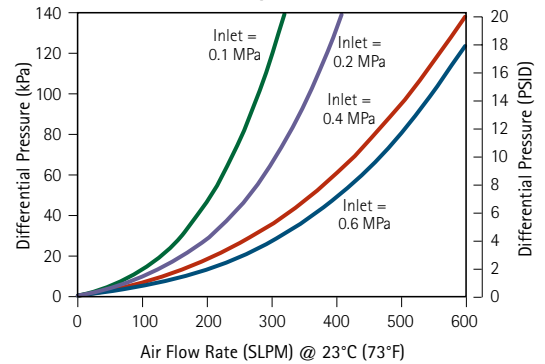

### Linegard MAX-FP 3/8" Fittings and 1/4" NPT

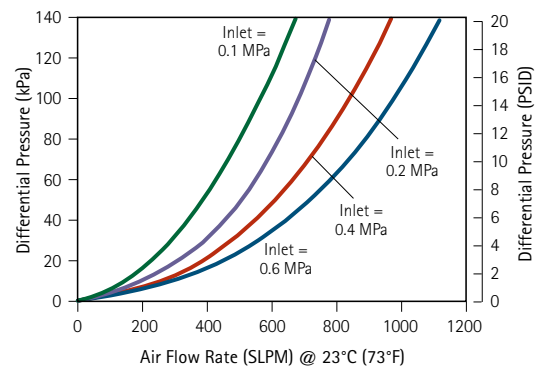

### Linegard MAX-FP 1/2" Fittings

